

primus

High Spin Industrial Washer Extractor FS 13



FEATURES

- Freestanding, high spin
- Coloured side panels
- Stainless steel drum and tub
- Easy to use (EC) microprocessor
- Extra large door opening ($\varnothing 41$ cm) for easy loading and unloading
- Large drain valve ($\varnothing 76$ mm)
- Easy access to all parts
- Patented soap hopper and drain valve (Liqui-Mix[®] system)
- Frequency controlled motor
- PowerWash[®] perforated lifting ribs: more mechanical action, lower water consumption

OPTIONS

- Stainless steel cabinet (AISI 304)
- Graphitronic[®] - new graphic display with almost unlimited possibilities as:
 - Communication interface enabling remote service
 - Multilingual microprocessor
 - Freely programmable
- Liquid soap connections
- Liquid soap pumps
- Coin operated timer
- SoftWash[®] version (wet cleaning)
- Water recovery kit
- Trace-Tech[®] traceability software and networking system

 TRACE-TECH[®]
Liqui-mix[®]

POWERWASH[®]

TYPE		FS 13
CAPACITY		
Drum volume	l	131
Capacity	kg	13
Drum diameter	mm	Ø650
DRUM SPEED		
Wash speed	rpm	45
Distribution speed	rpm	100
Spin speed	rpm	1000
G-factor		360
PROGRAMMER		
EC microprocessor		standard
Graphitronic® microprocessor		+
Coin meter (or tokens)		+
Coin counter		+
CABINET		
Coloured side panels		standard
Stainless steel AISI 304		+
CONNECTION		
		Freestanding (4xM10)
HEATING		
100% hot water	°C/°F	90/194
100% electrical	kW	6-9-12
Hot water and electrical		
Additional heating	kW	6-9-12
Steam additional heating	bar	1-3
Steam high pressure	bar	3-8
CONNECTION		
Electrical		1x220-240V 50/60Hz 3x220-240V 50/60Hz 3x380-415V+N 50Hz 3x380-415V 50Hz
Water inlet	inch	G 3/4"
Steam inlet	inch	G 1/2"
DIMENSIONS HxWxD	mm	1295x835x930
TRANSPORT DATA		
Gross weight		
Packing	kg	380
Net weight	kg	360
Volume (packed)		
Packing	m ³	1,16
Packing HxWxD	mm	1425x855x950

+ = Available
Standard = Standard execution

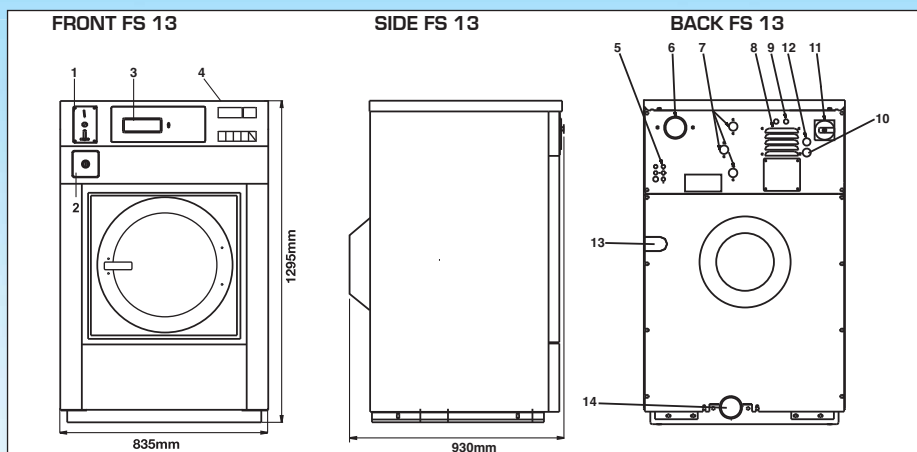

1. Coin meter
2. Coin box
3. Keyboard
4. Soap hopper
5. Liquid soap connection
6. Air vent
7. Water connection
8. Air vent holes, frequency inverter
9. Fuses
10. Electrical connection
11. Main switch
12. Electrical connection to liquid soap
13. Steam connection
14. Drain valve

The company Primus bvba preserves the right to change the machines and the specification in this leaflet at any time, without prior notice. Details and photographs are only for information and never binding.

www.primuslaundry.com

primus

Quality **without**
compromise

